

Mounting Accessories

Hazardous Rated Universal Mounting System

UL844 hazardous rated mounting system
 designed for Heavy Industrial environments
 Optimized Retrofit Accessories Designed for
 industrial applications



About

Lumisave has developed a unique Universal Mount suitable for any application or hazardous location. Our heavy duty mount can easily hold our heaviest Bay Light units while providing a chainable wiring connection that can have dry, wet, or hazloc connections. The UMS is intended to replace all existing Wall-Mount and Stanchion-Mount applications currently in place. The 3 section design allows for a straight (0°) or angled (22.5°) mounting by simply turning the center wiring compartment 180° at time of installation. With the addition of a wiring compartment located on the body of the mount, this allows for improved convenience of installation and maintenance. The 5 point 3/4" NPT wiring access points on the wall mount base allow for multiple Dry/Wet location wiring types and configurations including Teck Cable, BX cable, EMT and Rigid conduit.

Compliances

UL/cUL Listed to:

- UL 1598 Suitable for Wet Locations
- UL 844 Hazardous Locations

IP66



Features



Anodized Exterior: Durable and Corrosion-Resistant



Wiring Configuration Access Point



1-1/2" Threaded Stanchion Mount

For IES files, see website or contact Lumisave



UMS

Hazardous Rated Universal Mounting System



Dimensions

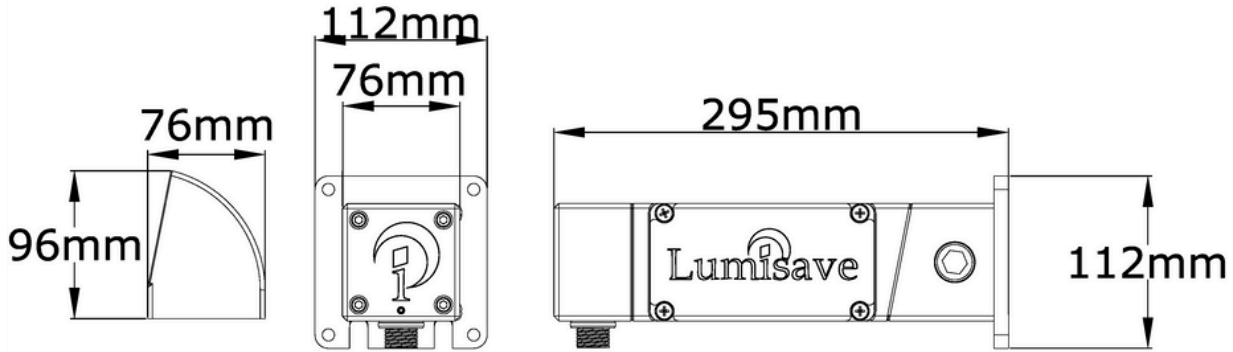

Connection Type



Dry Connection



Hazloc Connection



Wet Connection