



# SM420 SERIES

Stanchion Mount Available in 30, 60, & 80 Watt

## Key Features

The SM420 is our industrial stanchion mount product. Designed for use in the mining, oil & gas industry, conveyor belts and walkways. Our stanchion mounted lights are small, light weight and compact making them ideal for cat walk applications.

## Recommended Use

Industrial applications. Conveyor Belt, Stanchion Mount, Industrial walkways, Low mounting, Wet & Dry Locations, Storage Areas and Low Clearance. Suitable for wet and dry locations, the SM 420 series will illuminate your industrial walkways or hard to reach areas beautifully. Certified for general or hazardous locations.

## Advantages

- Production & quality control completed at Lumisave's local manufacturing facilities. - Every chip tested on site.
- Multi Chip has 80,000 Hours+ lifespan and produces 100 lumens per watt
- Hazardous Location Certified
- Rugged, weather-proof design
- 5 Year replacement warranty
- Up to 70% energy savings



## SM420 SERIES

**DIMENSIONS** - all measurements in millimetres

A		B					
		RS	RD	RA	RC	RN	DGW
30W	60	140	260	260	165	55	65
60W	135	140	260	260	165	55	65
80W	135	140	260	260	165	55	65
C		500	420	420	360	280	280

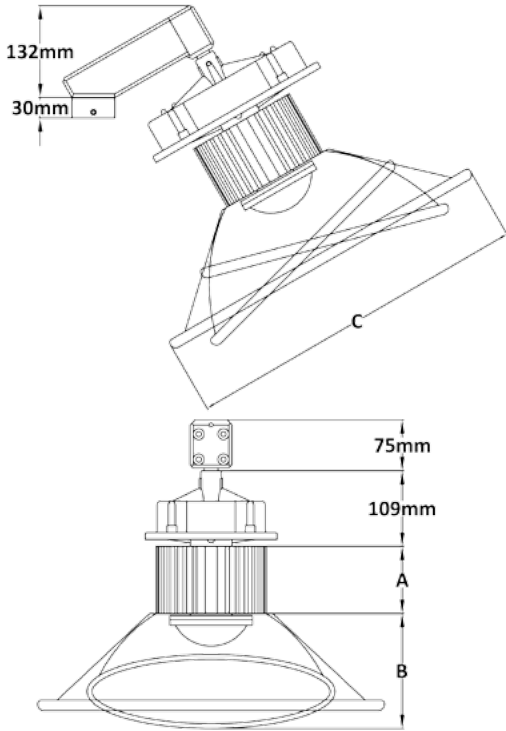

## Specifications

<b>MULTI Voltage</b>	120-227V** or 347-480V**
<b>Power Factor</b>	≤ 95%
<b>LED Luminous Efficiency</b>	100 (Lm/W)
<b>Colour Temperature</b>	5000K**
<b>Colour Rendering Index</b>	Ra > 70
<b>Maximum Intensity Angle</b>	≥ 120 Degree
<b>Work Temperature</b>	-40°C to + 40°C
<b>Work Humidity</b>	10% to 95% RH
<b>Chip Life Expectancy</b>	80,000 Hours (LM70)
<b>Fixture</b>	Black Aluminum Alloy Housing
<b>Lens</b>	Lexan
<b>Weight</b>	4.5 - 6.8 kg
<b>Protection</b>	IP65, Wet Location
<b>Approved</b>	Class 1 Div II, Class 2 Div II, RoHS, CE, cETLus. Tested to CSA and UL Standards
<b>**Lumisave can produce additional specifications. Available upon request</b>	

Sample Order Number: LS-SM420-30W--MV-DC-RC-W15-MS-H1

LS-SM420											
SERIES	WATTAGE	VOLTAGE	LENS	REFLECTOR	CABLE WHIP	MOUNTING	HazLoc				
LS-SM420	30W 60W 80W	MV HV	120-277V DC 347-480V* DF DGW GLASS DOME c/w Wire Guard	CLEAR DOME RC FROSTED DOME RS GLASS DOME RN	CUTOFF REFLECTOR SHALLOW ALUMINUM NO REFLECTOR	W15 W(X) 15' WHIP CUSTOM WHIP	MS MA	STATION MOUNT 1-1/2" ADAPTER	H0 H1	NON HAZARDOUS HAZARDOUS	

\*Call Lumisave for more details about custom orders 1-855-563-7284