

LBL SERIES

50W | 100W | 150W | 200W
General Rated LED Linear Bay Light

High Lumen Output
Optimized Retrofit Accessories Designed for industrial applications



-40°C | +40°C

Key Applications

- Recreational Facilities
- Commercial Stores
- General Lighting
- Processing Facilities
- Manufacturing
- Storage
- Wet Locations
- Low/Medium/High Mounting
- Warehousing
- Area Lighting

Compliances

UL/cUL Listed to:

- UL 1598 Suitable for Wet Locations

IP65

Specifications

Voltage	120-277V or 347-480V
Power Factor	<95%
Efficacy	130 Lumens/Watt
Lumen Output	LS-LBL-50W: 6,500 LM LS-LBL-100W: 13,000 LM LS-LBL-150W: 19,500 LM LS-LBL-200W: 26,00 LM
Colour Temp.	5000K Standard Custom CCT Available
CRI	RA>80
Frequency	50-60Hz
LED Diodes	Phillips 3030
Power Supply	Meanwell
Optics	30°x70° / 60°x100° / 120°
Operating Temp	-40°C to +40°C
Weight	LS-LBL-50W: 5 LBS LS-LBL-100W: 9 LBS LS-LBL-150W: 12 LBS LS-LBL-200W: 17 LBS
Connections	1/2" NPT
Mounting	Surface Mounted (Standard)
Warranty	5 Year Standard



For IES files, see website or contact Lumisave



LBL SERIES

General Rated LED Linear Bay Light



Dimensions

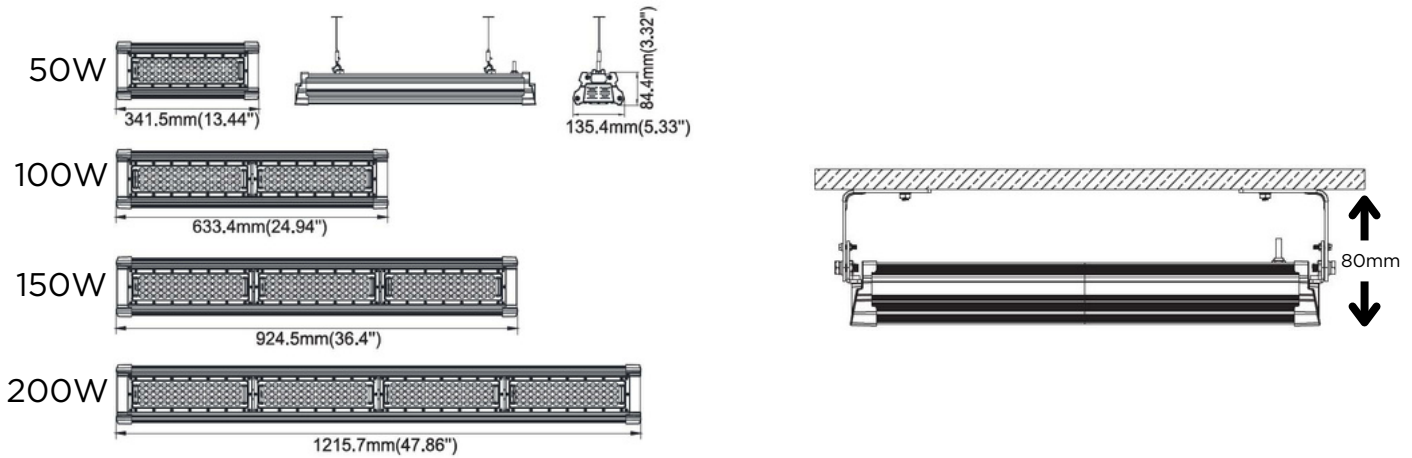

Ordering Information

Example: LS-LBL-50W-MV-5K-NB-W7-MS

Model	Wattage	Voltage	Colour Temp	Optics	Cable	Mounting
LS-LBL	50W	MV	5K	NB	W7	MS
	100W	HV	CTM	MB	W(X)	
	150W			WB		
	200W					

Wattage	Volatge	Colour Temp	Optics	Cable	Mounting
50W	MV 120-277Vac	5K 5000K (Standard)	NB Narrow Beam (30°x70°)	W7 7' Cabtyre	MS Standard Kit
100W	HV 277-480Vac	CTM Custom (Upon Request)	MB Medium Beam (60°x100°)	W(X) Custom	
150W			WB Wide Beam (120°)		
200W					

Notes

- 1 Replace (X) in Cable with desired length in feet
- 2 Special project pricing and support available upon inquiry
- 3 Product customization available upon consultation

Mounting Accessories



Surface Mounted



Suspended