



## BL550 SERIES

200W

### Industrial LED Bay Light

UL1598 rated bay light designed for Heavy Industrial environments  
High Lumen Output  
Optimized Accessories Designed for industrial applications



### Key Applications

- Warehousing Buildings
- Sports Arenas
- Recreational Facilities
- Commercial Stores
- High Mounted Applications
- General Lighting
- Processing Facilities
- Manufacturing
- Storage

### Compliances

UL/cUL Listed to:

- UL 1598 Suitable for Wet Locations

IP66



### Specifications

<b>Voltage</b>	120-277V or 347-480V
<b>Power Factor</b>	<95%
<b>Efficacy</b>	150 Lumens/Watt
<b>Lumen Output</b>	27,000 LM
<b>Colour Temp.</b>	5700K Standard
<b>CRI</b>	RA>70
<b>Frequency</b>	50-60Hz
<b>LED Diodes</b>	Lumileds 3030
<b>Power Supply</b>	Meanwell
<b>Optics</b>	120°   90°   60°
<b>Operating Temp</b>	-40°C to +40°C
<b>Weight</b>	16.5 Lbs
<b>Connections</b>	1/2" NPT
<b>Mounting</b>	Hook Mount (Standard) Pendant Mount Safety Cable
<b>Warranty</b>	5 Year Standard

For IES files, see website or contact Lumisave



# BL550 SERIES

Industrial LED Bay Light



## Dimensions

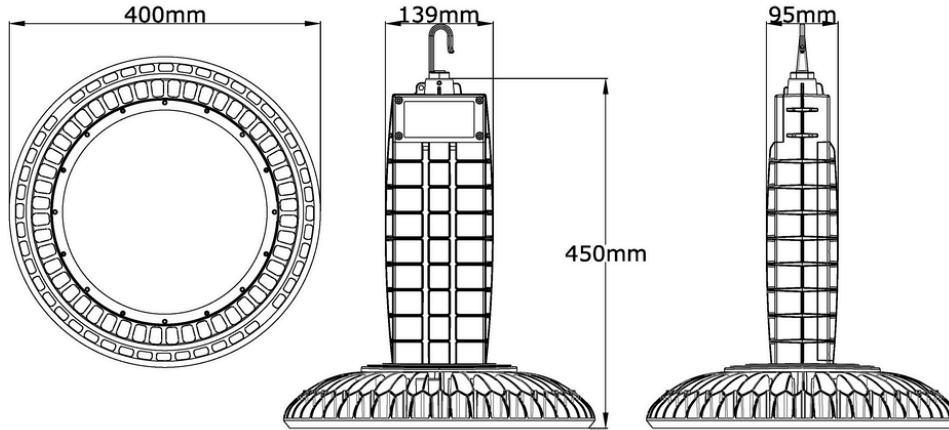

**Example:** LS-BL550-27L-MV-LW-MH-HO

Model	Lumens	Voltage	Lens	Mounting	Hazloc
LS-BL550	27L	MV	LW	MH	HO
		HV	LM	MP	
			LN		

Wattage	Volatge	Lens	Mounting	Hazloc
<b>27L</b> 27,000 LM	<b>MV</b> 120-277V	<b>LW</b> Wide Lens (120°)	<b>MH</b> Hook Mount	<b>HO</b> Non Hazardous
	<b>HV</b> 347-480V	<b>LM</b> Medium Lens (90°)	<b>MP</b> Pendant Mount	
		<b>LN</b> Narrow Lens (60°)		

### Notes

- 1 Special project pricing and support available upon inquiry
- 2 Product customization available upon consultation

## Mounting

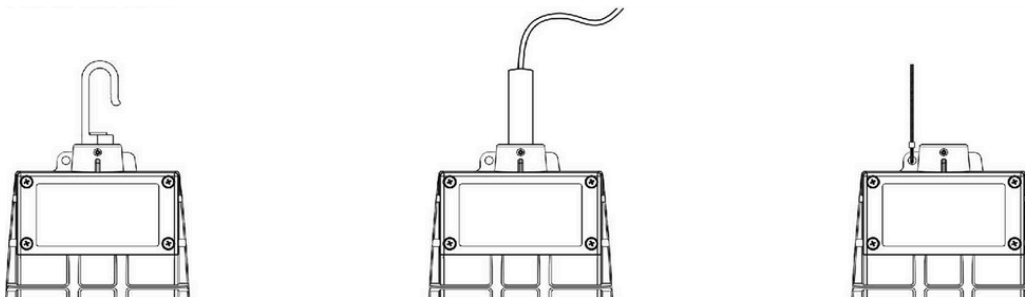

Hook Mount (MH)

Pendant Mount (MH)

Safety Cable