



# BL520 SERIES

Baylight Available in 100, 150, & 200 Watt

## Key Features

The high-powered LED chip offers superior brightness, proven to eliminate safety concerns while providing exceptional light quality for highly productive environments. It can be mounted from above or by using a wall mount. It is useful for high humidity workplaces as well as frigid and hostile locations

## Recommended Use

Use the 150/200 watt Bay Series LED to replace your old 400 watt lighting system. This 1-for-1 HID equivalent eliminates your relamping cost, reduces energy consumption by up to 60%, and delivers more light more efficiently. Use in warehouses, manufacturing plants, where long life source is required, high mounting height, chemical plants, or storage buildings.

## Advantages

- Production & quality control completed at Lumisave's local manufacturing facilities.
- Every chip tested on site.
- Multi Chip has 80,000 Hours+ lifespan and produces 100 lumens per watt
- Hazardous Location Certified
- Rugged, weather-proof design
- 5 Year replacement warranty
- Up to 70% energy savings



## BL520 SERIES

DIMENSIONS - all measurements in millimetres

A		B					
		RS	RD	RA	RC	RN	DGW
100W	150	140	260	260	165	55	65
150W	180	140	260	260	165	55	65
200W	250	140	260	260	165	55	65
C		500	420	420	360	280	280

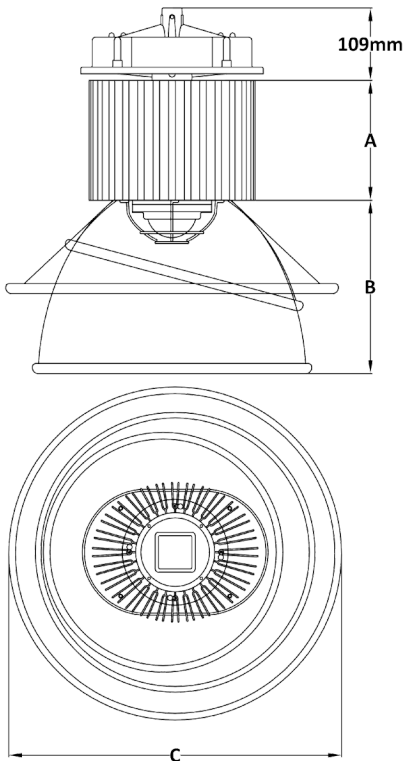

## Specifications

MULTI Voltage	120-277V** or 347-480V**
Power Factor	≤ 95%
LED Luminous Efficiency	100 (Lm/W)
Colour Temperature	5000K**
Colour Rendering Index	Ra > 70
Maximum Intensity Angle	≥ 160 Degree
Work Temperature	-40°C to + 40°C
Work Humidity	10% to 95% RH
Chip Life Expectancy	80,000 Hours (LM70)
Fixture	Black Aluminum Alloy Housing
Lens	Tempered Glass**
Weight	9 - 12.2 kg
Protection	IP65, Wet Location
Approved	Class 1 Div II, Class 2 Div II, RoHS, CE, cETLus. Tested to CSA and UL Standards
**Lumisave can produce additional specifications. Available upon request	

Sample Order Number: LS-BL520-100W-HV-DG-RS-W7-MH-H1

SERIES	WATTAGE	VOLTAGE	LENS	REFLECTOR	CABLE WHIP	MOUNTING	HazLoc
LS-BL520	100W 150W 200W	MV HV	DG DGW c/w WIRE GAURD	RS SHALLOW ALUMINUM RD DEEP ALUMINUM RA LEXAN REFLECTOR RC CUTOFF REFLECTOR RN NO REFLECTOR	W7 W(X) 7'WHIP CUSTOM WHIP	MH MALE THREAD HOOK MP 1/2" PENDANT MOUNT MW WALL MOUNT UAP Universal Mount	H0 NON HAZARDOUS H1 HAZARDOUS

\*Call Lumisave for more details about custom orders 1-855-563-7284