



HEAVY INDUSTRIAL SERIES

FL375 & FL395

INDUSTRIAL PROTECTION, INDUSTRIAL STRENGTH

The Industrial LED fixture series built from the ground up by Lumisave, are designed to stand up to extreme conditions seen in the coal industry and other heavy industrial applications. The goal was to create a series of fixtures which offer more protection and are able to withstand the toughest conditions.

HEAVY INDUSTRIAL SERIES

- Heavy Duty Industrial Applications
- Indoor & Outdoor Flood Applications
- Wet & Dry Locations
- High Vibrations
- Oil & Gas Industry
- Mining Industry
- Heavy Equipment
- Extreme Temperatures
- Humidity

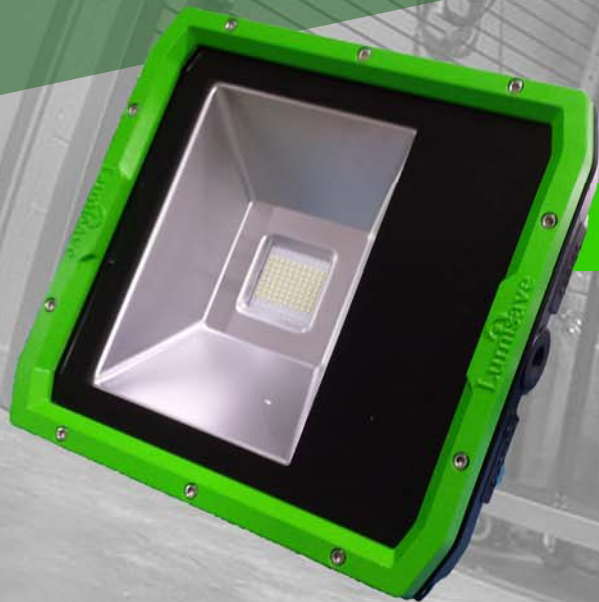

ADVANTAGES

- Designed, Built, and tested in Canada
- Epoxy Filled Driver
- Long Life - 80,000+ Hour Lifespan
- Rated 150 Lumens/Watt Output
- Hazardous Location Certified
- Rugged, Weather-Proof Design
- 5-year Warranty
- Fully Customizable

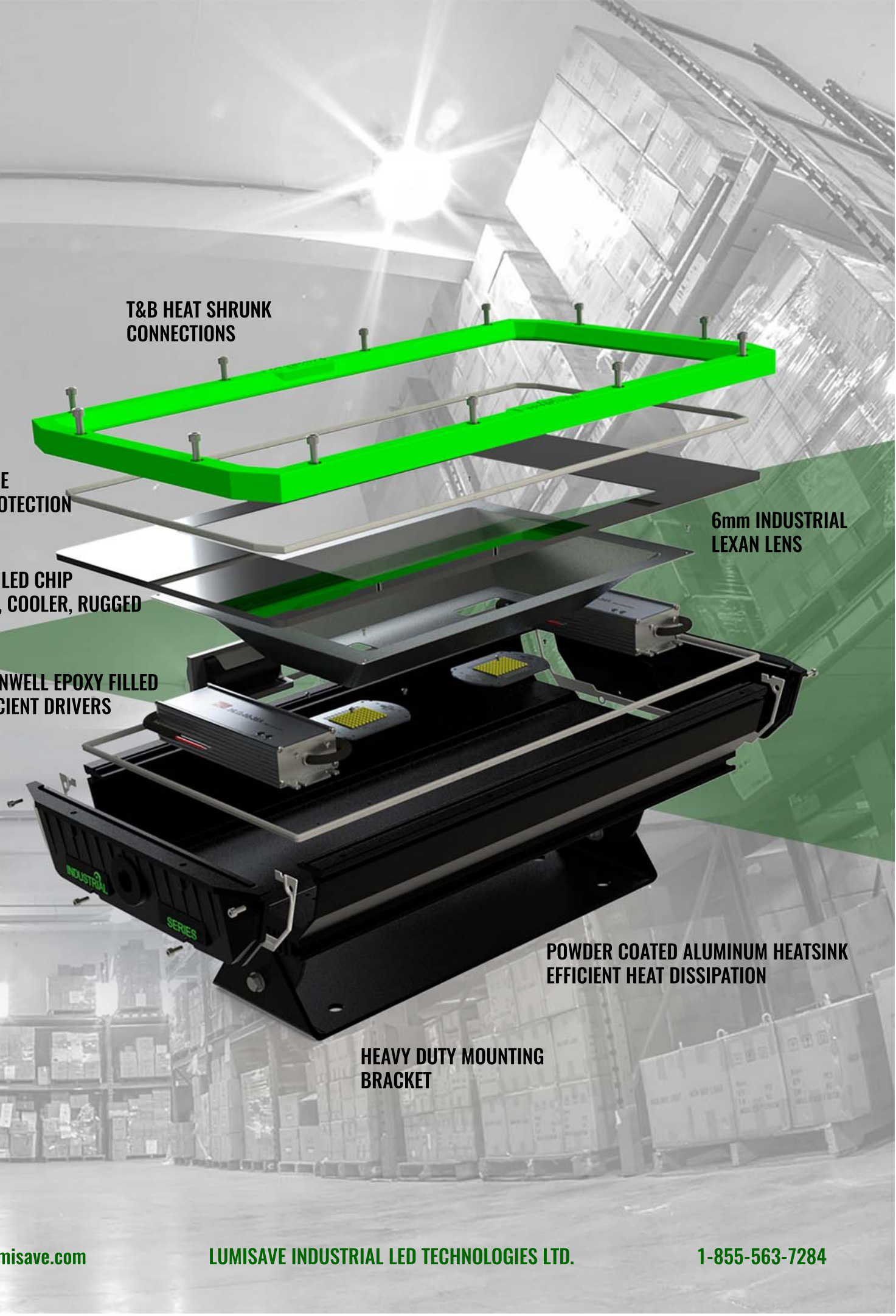

T&B HEAT SHRUNK CONNECTIONS

LITTLE FUSE SURGE PROTECTION

SAMSUNG LED CHIP BRIGHTER, COOLER, RUGGED

DUAL MEANWELL EPOXY FILLED HIGH EFFICIENT DRIVERS

6mm INDUSTRIAL LEXAN LENS

POWDER COATED ALUMINUM HEATSINK EFFICIENT HEAT DISSIPATION

HEAVY DUTY MOUNTING BRACKET